



Produttore di ghiaccio con contenitore incorporato - Sistema a granulare
Produzione giornaliera fino a 66 kg

Hotel	
Ristoranti	
Fast food	
Bar	
Discoteche	
Mercati ittici	
Supermercati	
Medicale & SPA	
Industrie	

► Position n°



► Features & Plus

- Ghiaccio granulare 80-82% dry
- 1L (acqua) = 1kg (ghiaccio) - solo A
- Carrozzeria AISI 304 Scotch Brite
- Classe Tropicale + 43° C
- Filtro Aria smontabile e pullbile
- Evaporatore in Acciaio AISI 304
- Condensazione aria o acqua
- Interno arrotondato per facile pulizia
- Isolamento contenitore HCFC-Free
- Bacinella acqua sigillata antipolvere
- RoHS Free
- Sportello Isolato con apertura a scomparsa
- Funzionamento elettromeccanico
- Interruttore ON/OFF
- Caricamento automatico dell'acqua
- Voltaggio standard e voltaggi speciali



Carrozzeria AISI 304 Scotch Brite



Filtro Aria smontabile e pullbile



Evaporatore in Acciaio AISI 304



Bacinella acqua sigillata antipolvere



Sportello Isolato con apertura a scomparsa



Ice Flakes

GB 601



Produttore di ghiaccio con contenitore incorporato - Sistema a granulare
Produzione giornaliera fino a 66 kg

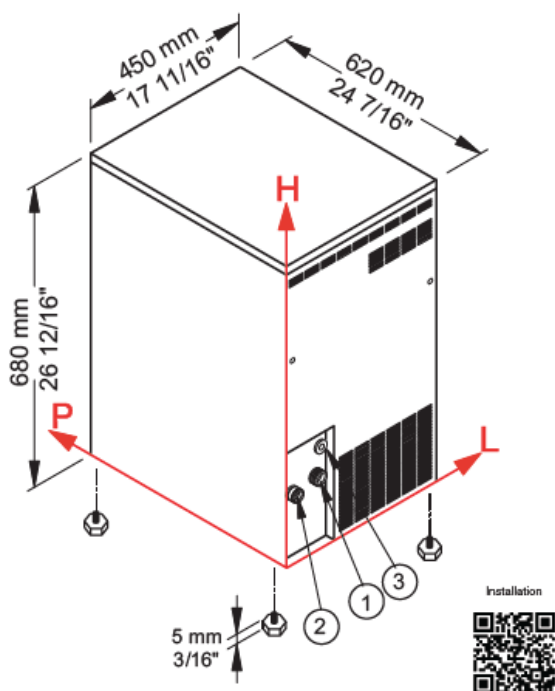

► **Condizioni d'installazione**

- Installazione: **Interna**

	Min	Max
Temperatura ambiente	+10° C / +50° F	+43° C / 110° F
Temperatura acqua	+3° C / +37° F	+32° C / +90° F
Voltaggio	-10%	+10%
Pres. acqua in ingresso	1bar (14 psi)	6bar (84 psi)

► **Performance**

		Temperatura acqua					
		7° C	45° F	15° C	60° F	21° C	70° F
Temperatura aria	10° C	66 kg					
	50° F		146 lbs				
	21° C			60 kg			
	70° F				132 lbs		
	32° C					51 kg	
	90° F						112 lbs

► **Connessioni**

Le misure sono riferite all'angolo del retro in basso a sinistra (L-H-Ø)

- ① Ingresso acqua: 106 mm / 4 3/16" - 135 mm / 5 5/16" - 3/4" ② Scarico acqua: 55 mm / 2 3/16" - 140 mm / 5 8/16" - 24 mm / 15/16"
 ③ Connessione elettrica: 114 mm / 4 8/16" - 218 mm / 8 9/16"

► **Dati tecnici**

Produzione in 24h	60 kg / 132 lbs	Consumo d'acqua	A: 1 l/kg - 12,0 gal/100 lbs
Capacità contenitore, fino a	9 kg / 20 lbs		W: 5,3 l/kg - 63,5 gal/100 lbs
Condensazione	A - W	Dimensioni (L-P-H mm)	450 - 620 - 680
Refrigerante	R452A	(L-P-H in)	17 11/16 - 24 7/16 - 26 12/16
Voltaggio standard	220-240 V ~ 50 Hz	Dimensioni Imballo (L-P-H mm)	505 - 675 - 850
Potenza media assorbita	420 W	(L-P-H in)	19 14/16 - 26 9/16 - 33 7/16
Fusibile	10 A	Peso netto	56 kg / 123 lbs
Finitura	Acciaio Inox 18/8, scotch brite	Peso lordo	64 kg / 141 lbs

Tutti i dati tecnici sono da considerarsi validi alle seguenti condizioni:
 Dimensioni esclusi i piedini
 Temperatura ambiente +21° C
 Temperatura acqua +15° C
 Potenza media assorbita a +43° C (Voltaggio standard)